

INDUSTRIAL DIESEL ENGINE

Kubota OC Series (1-Cylinder)

OC60-E3

EPA/CARB
TIER
4

Rated Power

4.5 kW @ 3600 rpm



Photograph may show non-standard equipment.

Performance Curves

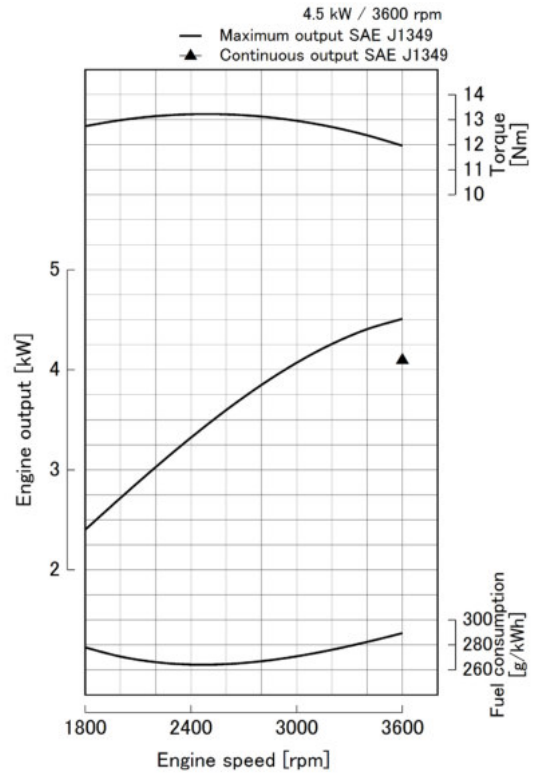

Features and Benefits

Emissions

The Kubota OC60 engine complies with EPA Tier 4 emissions regulations.

Durable Power

This engine offers a seamless transition from E2 to E4 by totally maintaining the same performance and physical characteristics.

Clean and Quiet Power

The Kubota OC series is a unique engine that has light-weight and compact features of an air-cooled engine together with the low noise, durability and clean exhaust emission of a water-cooled diesel engine. With ACTV (Advanced Cooling Three Vortex) system, the cylinder block is air-cooled, whereas the combustion area of the cylinder head is oil-cooled.

For Earth, For Life
Kubota

OC60-E3

Engine Specifications

Engine model		OC60-E3
Emission regulation		EPA/CARB Tier 4 level
Type		Vertical, liquid-cooled 4-cycle diesel engine
Cylinders		1
Bore and stroke	mm (in)	72.0 x 68.0 (2.83 x 2.68)
Displacement	L (cu.in)	0.276 (16.8)
Maximum output / speed *1	kW (HP) / rpm	4.5 (6.0) / 3600
Continuous output / speed *1	kW (HP) / rpm	4.1 (5.5) / 3600
Maximum torque / speed	Nm (lb-ft) / rpm	13.2 (9.7) / 2000 to 2600
Combustion system		Indirect Injection *2
Fuel tank capacity	L (U.S.gal)	3.5 (0.92)
Lubricating oil capacity	L (U.S.gal)	1.3 (0.34)
Starter capacity	V-kW	12-0.7
Charging dynamo	V-W	12-48 (L1 model: 12-170)
Length x Width x Height	mm (in)	403 x 461 x 458 (15.9 x 18.1 x 18.0)
Dry weight *2	kg (lbs)	38 (84)

Specification is subject to change without notice.
 Dry weight is according to Kubota's standard specification.
 When specification varies, the weight will vary accordingly.

*1: SAE J1349 net intermittent
 *2: Three Vortex Combustion System (TVCS)

Dimensions

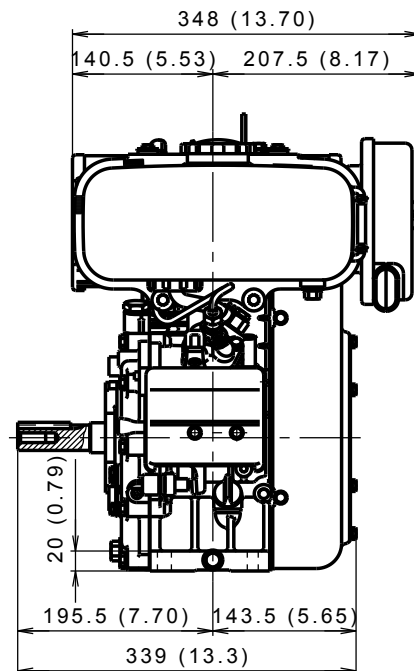
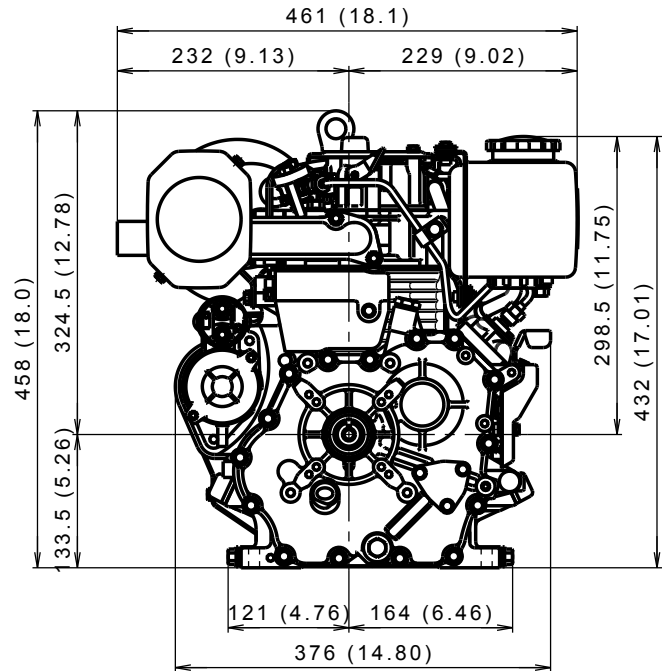

Kubota Corporation

2-47, Shikitsuhigashi 1-chome Naniwa-ku, Osaka, 556-8601 Japan
<https://global.engine.kubota.co.jp/en/>

ASP-OC60-E31806-R1-I-178040

OC60

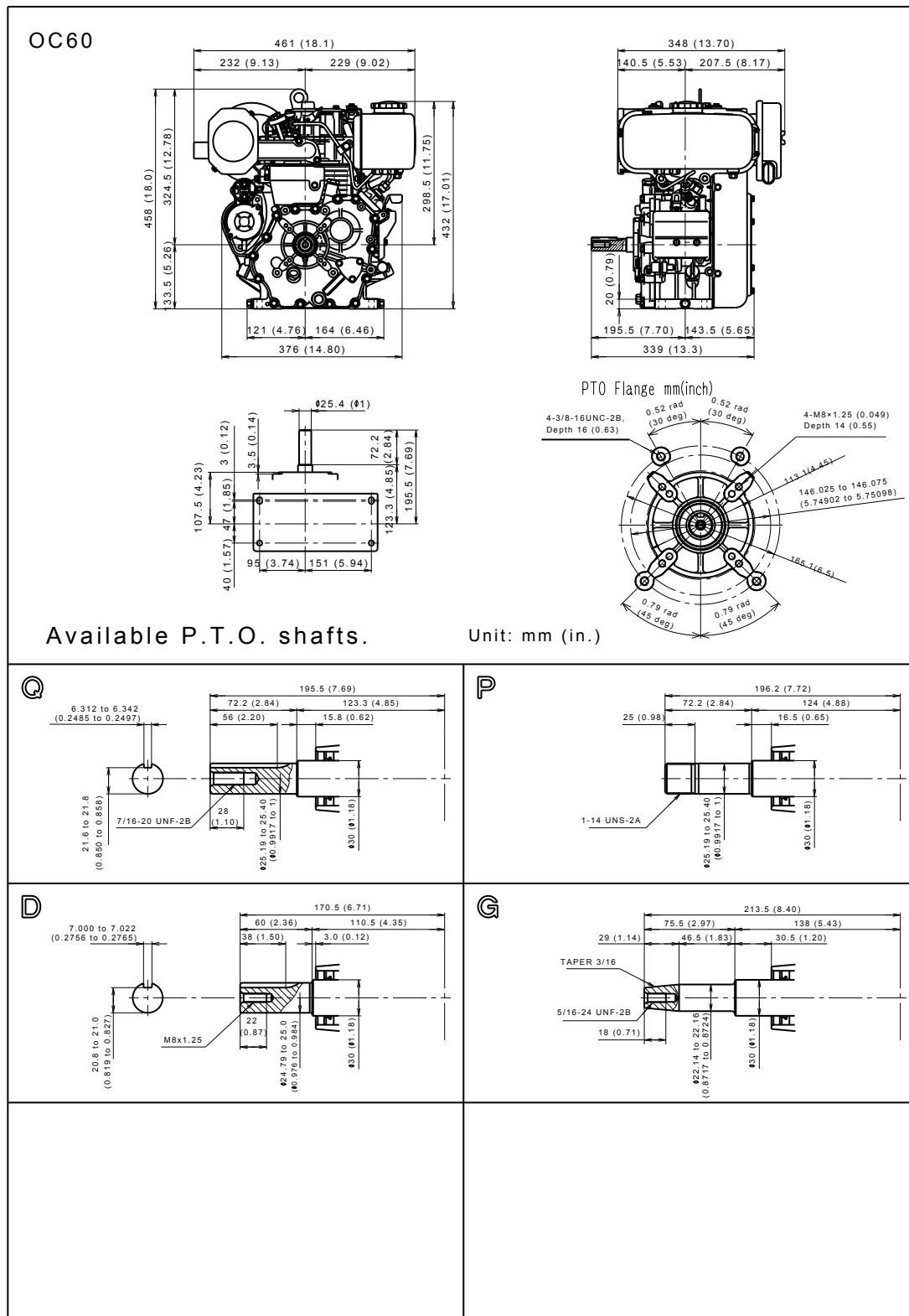

Kubota Corporation

2-47, Shikitsu Higashi 1-chome Naniwa-ku, Osaka, 556-8601 Japan

<https://engine.kubota.com/en/>

ASP-OC60-E31806-R1-I-178040