

## INDUSTRIAL DIESEL ENGINE

### Kubota 03 Series (3-Cylinder)

# D1703-M-E3B



#### Rated Power

## 26.1 kW @ 2800 rpm



Photograph may show non-standard equipment.

#### Performance Curves

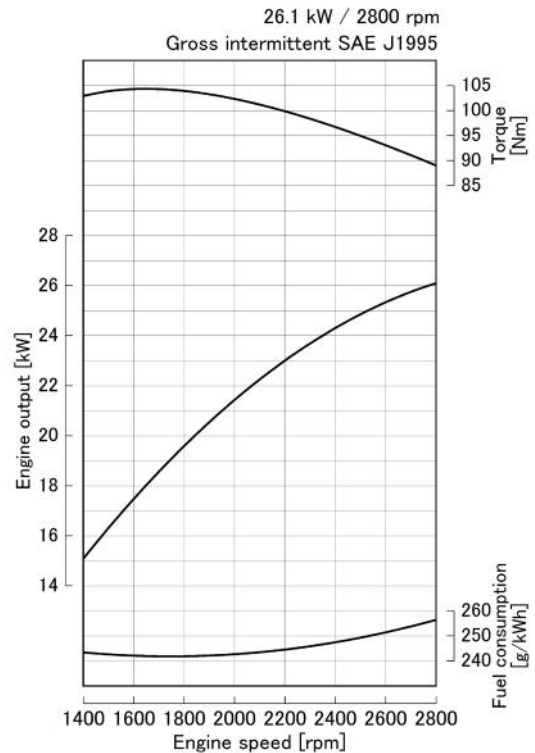

#### Features and Benefits

##### Emissions

The D1703-M engine complies with the EPA / CARB interim Tier 4 + EU Stage IIIA emissions regulations.

##### Durable Power

The Kubota 03-M Series is well known for its industrial applications. With numerous features such as a built-in solenoid, low fan position, and single-side serviceability, this engine provides excellent performance and flexibility.

The cooling water passages between the cylinder bores features Kubota's original casting technology as a countermeasure against the heat load caused by high power density, providing both superior endurance and reliable engine performance.

The D1503-M engine offers a seamless transition from EPA Tier 2 to EPA Interim Tier 4 by maintaining the same footprint and hardware mounting points with minimal performance changes from EPA Tier 2 engines.

##### Clean and Quiet Power

Kubota's original E-TVCS (Three Vortex Combustion System) has been improved. The airflow, combustion chamber, and piston recess have been optimized to provide lower particulate matter (PM) levels.

The half-float valve cover and MoS<sub>2</sub>-coated pistons reduce noise levels compared to conventional diesel engines and decrease vibrations transmitted from the valve area.

##### Options

Kubota 03-M Series engines offer side power take-off (PTO) in response to the trend of the use of hydraulic control devices in industrial machines. A hydraulic pump can be installed at the two side PTO locations.

For Earth, For Life  
**Kubota**

# D1703-M-E3B

## Engine Specifications

<b>Engine model</b>		D1703-M-E3B
<b>Emission regulation</b>		EPA/CARB interim Tier 4 level + EU Stage IIIA
<b>Type</b>		Vertical, water cooled 4-cycle diesel engine
<b>Cylinders</b>		3
<b>Bore and stroke</b>	mm (in)	87.0 x 92.4 (3.43 x 3.64)
<b>Displacement</b>	L (cu.in)	1.647 (100.5)
<b>Aspiration</b>		Naturally aspirated
<b>Aftertreatment</b>		-
<b>Rated output / speed</b> *1	kW (HP) / rpm	26.1 (35.0) / 2800
<b>Maximum torque / speed</b> *1	Nm (lb-ft) / rpm	104.3 (76.9) / 1600
<b>Combustion system</b>		Indirect injection
<b>Fuel system</b>		In-line pump
<b>Length x Width x Height</b> *2 (without aftertreatment unit)	mm (in)	547 x 495 x 679 (21.5 x 19.5 x 26.7)
<b>Length x Width x Height</b> *3 (with aftertreatment unit)	mm (in)	-
<b>Dry weight</b> *3	kg (lbs)	148 (326)

Specifications are subject to change without notice.  
Dimensions and dry weight are according to Kubota's standard specification.  
Dimensions and weight depend on completed specifications.

\*1: SAE J1995 gross intermittent

\*2: Exclude cooling fan and exclude aftertreatment unit

\*3: Exclude cooling fan and include aftertreatment unit on engine

## Dimensions

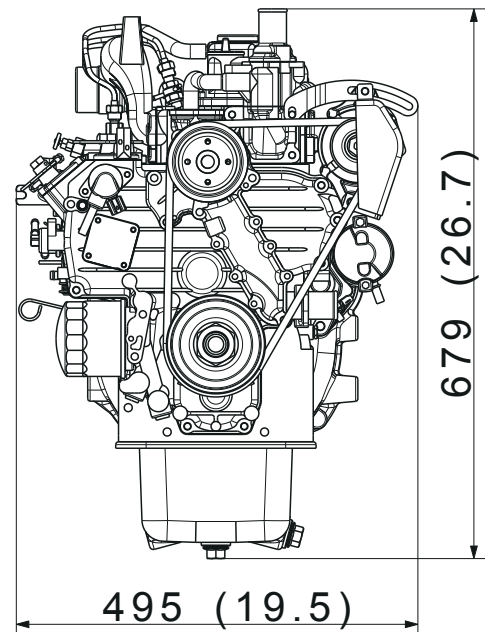
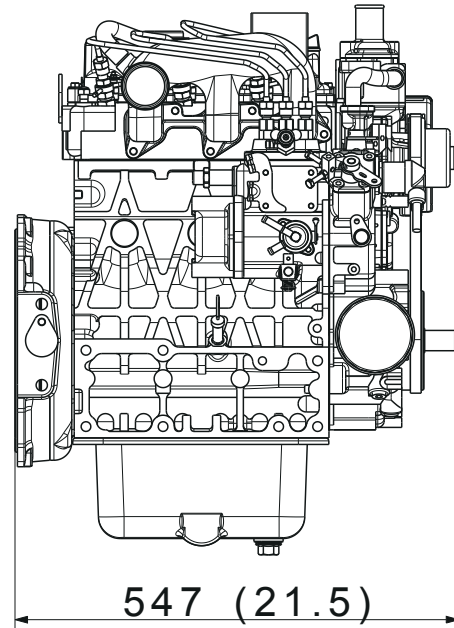

## Kubota Corporation

2-47, Shikitsu Higashi 1-chome Naniwa-ku, Osaka, 556-8601 Japan

<https://engine.kubota.com/en/>

ASP-D1703-M-E3B1808-R1-I