

INDUSTRIAL DIESEL ENGINE

Kubota V3 Series (4-Cylinder)

V3800-TIE4B



Rated Power

55.4 kW @ 2200 rpm

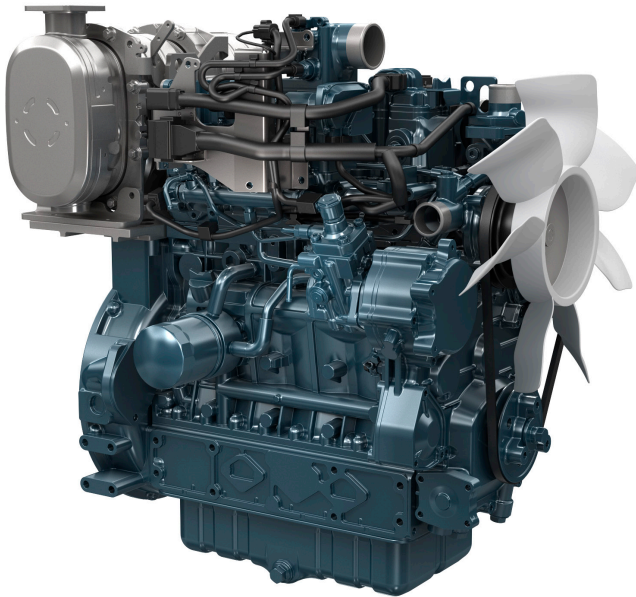

Photograph may show non-standard equipment.

Performance Curves

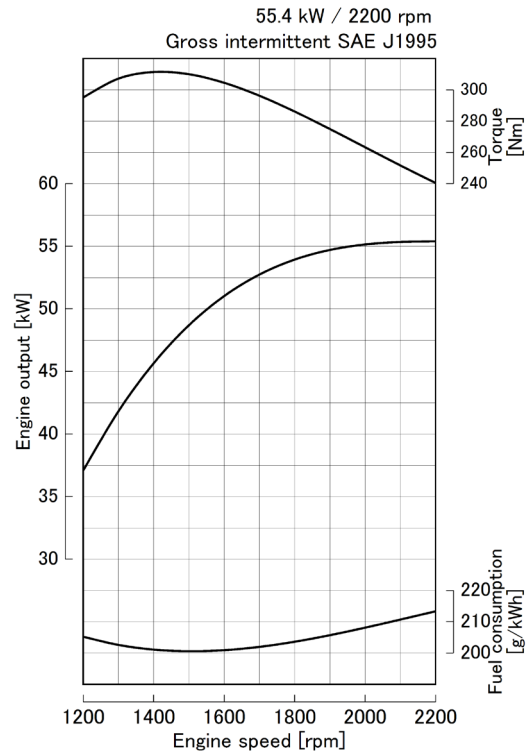

Features and Benefits

Proven Reliability and Technology

The latest technology and strong performance—two things customers expect from Kubota engines. We continue to provide both through the pursuit of excellence in emissions compliance and progress toward fully electronic controlled engines. These key areas allow Kubota to offer flexibility in the products and services we provide to customers worldwide.

Clean and Quiet Power

A Common Rail System has made it possible to optimize combustion and create a more durable and quieter engine with higher fuel efficiency. This engine model is available with DOC aftertreatment.

Emissions Compliance

Meeting rigid emissions regulations can be a challenge for any company. V3800-TIE4B engines have been designed to comply with stringent regulations: EPA / CARB interim Tier 4 level + EU Stage IIIB level. In addition, innovative emissions solutions, such as the use of aftertreatment units, have also been integrated into the engines.

Flexibility

Flexibility is a must when working with customers in different countries who have different engine needs. Since Kubota V3 Series engines have evolved along every step in meeting the requirements of each EPA Tier, we are able to provide our customers worldwide with engines certified for the appropriate emissions regulations. In addition, we have designed aftertreatment units with minimum impact for easy installation.

Trust

Kubota V3 Series engines are the ideal solution for your company's global marketing strategy. We continuously strive to meet your needs with the experience and expertise that is your due.

For Earth, For Life

V3800-TIE4B

Engine Specifications

Engine model		V3800-TIE4B
Emission regulation		EPA/CARB Tier 4 + EU Stage IIIB
Type		Vertical, water cooled 4-cycle diesel engine
Cylinders		4
Bore and stroke	mm (in)	100.0 x 120.0 (3.937 x 4.724)
Displacement	L (cu.in)	3.769 (230.0)
Aspiration		Turbocharged + Turbo After Cooler
Aftertreatment		DOC
Rated output / speed *1	kW (HP) / rpm	55.4 (74.3) / 2200
Maximum torque / speed *1	Nm (lb-ft) / rpm	310.0 (228.7) / 1500
Combustion system		Direct injection
Fuel system		Common rail system
Length x Width x Height *2 (without aftertreatment unit)	mm (in)	699 x 617 x 837 (27.5 x 24.3 x 33.0)
Length x Width x Height *3 (with aftertreatment unit)	mm (in)	845 x 617 x 852 (33.3 x 24.3 x 33.5)
Dry weight *3	kg (lbs)	324 (714)

Specifications are subject to change without notice.

DOC: Diesel Oxidation Catalyst

Dimensions and dry weight are according to Kubota's standard specification.

Dimensions and weight depend on completed specifications.

*1: SAE J1995 gross intermittent

*2: Exclude cooling fan and exclude aftertreatment unit

*3: Exclude cooling fan and include aftertreatment unit on engine

Dimensions

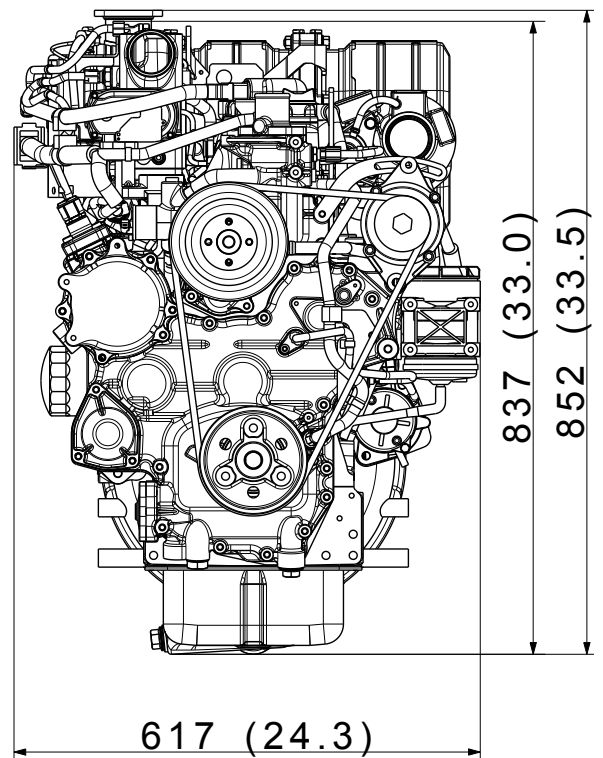
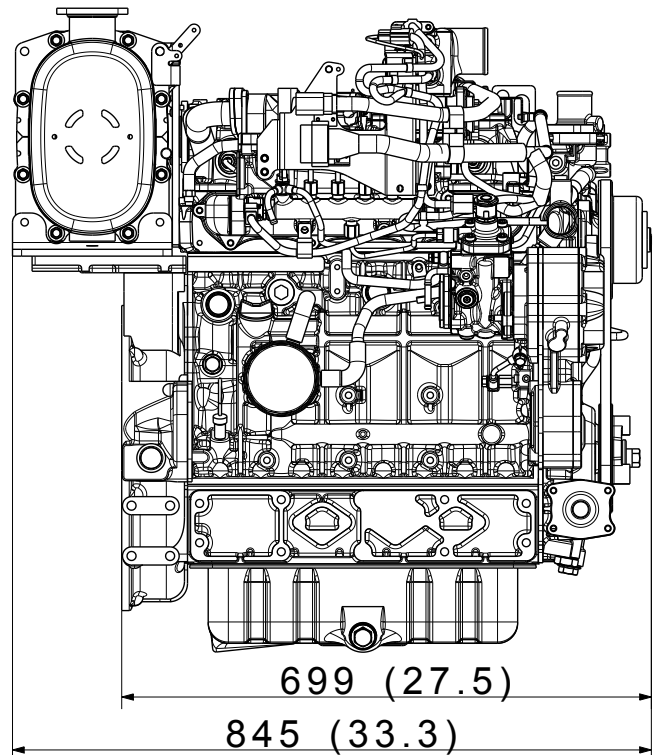

Kubota Corporation

2-47, Shikitsu Higashi 1-chome Naniwa-ku, Osaka, 556-8601 Japan

<https://engine.kubota.com/en/>

ASP-V3800-TIE4B1808-R1-I