

INDUSTRIAL DIESEL ENGINE

Kubota OC Series (1-Cylinder)

OC95-E3

EPA/CARB
TIER
4

Rated Power

7.0 kW @ 3600 rpm



Photograph may show non-standard equipment.

Performance Curves

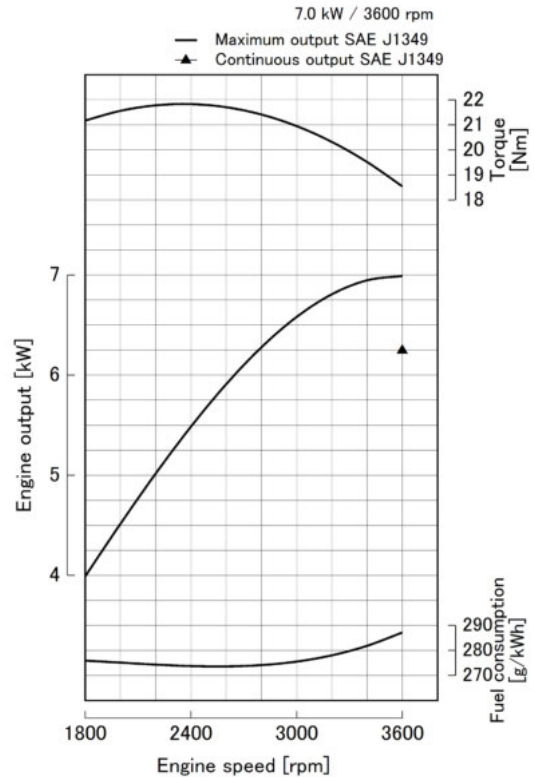

Features and Benefits

Emissions

The Kubota OC95 engine complies with EPA/CARB Tier 4 emissions regulations.

Durable Power

This engine offers a seamless transition from E2 to E4 by totally maintaining the same performance and physical characteristics.

Clean and Quiet Power

The Kubota OC series is a unique engine that has light-weight and compact features of an air-cooled engine together with the low noise, durability and clean exhaust emission of a water-cooled diesel engine. With ACTV (Advanced Cooling Three Vortex) system, the cylinder block is air-cooled, whereas the combustion area of the cylinder head is oil-cooled.

For Earth, For Life
Kubota

OC95-E3

Engine Specifications

Engine model	OC95-E3	
Emission regulation	EPA/CARB Tier 4 level	
Type	Vertical, liquid-cooled 4-cycle diesel engine	
Cylinders	1	
Bore and stroke	mm (in)	83.0 x 77.0 (3.27 x 3.03)
Displacement	L (cu.in)	0.416 (25.4)
Maximum output / speed *1	kW (HP) / rpm	7.0 (9.4) / 3600
Continuous output / speed *1	kW (HP) / rpm	6.25 (8.38) / 3600
Maximum torque / speed	Nm (lb-ft) / rpm	21.6 (15.9) / 2300
Combustion system	Indirect Injection *2	
Fuel tank capacity	L (U.S.gal)	5.5 (1.5)
Lubricating oil capacity	L (U.S.gal)	1.7 (0.45)
Starter capacity	V-kW	12-1.2
Charging dynamo	V-W	12-48 (L1 model: 12-170)
Length x Width x Height	mm (in)	451 x 503 x 501 (17.8 x 19.8 x 19.7)
Dry weight *2	kg (lbs)	56 (120)

Specification is subject to change without notice.
 Dry weight is according to Kubota's standard specification.
 When specification varies, the weight will vary accordingly.

*1: SAE J1349 net intermittent
 *2: Three Vortex Combustion System (TVCS)

Dimensions

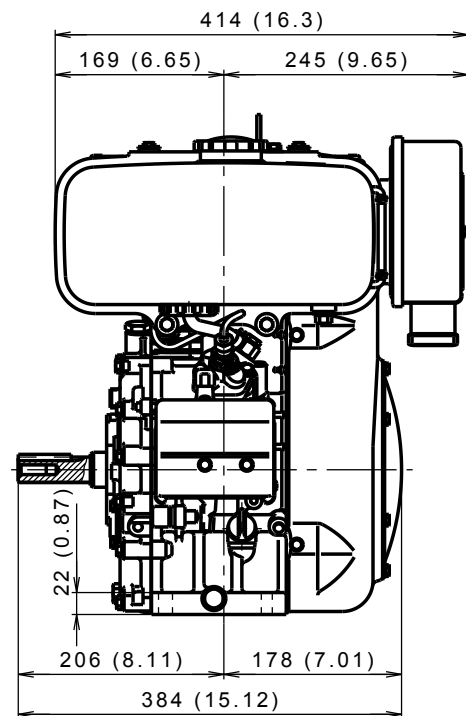
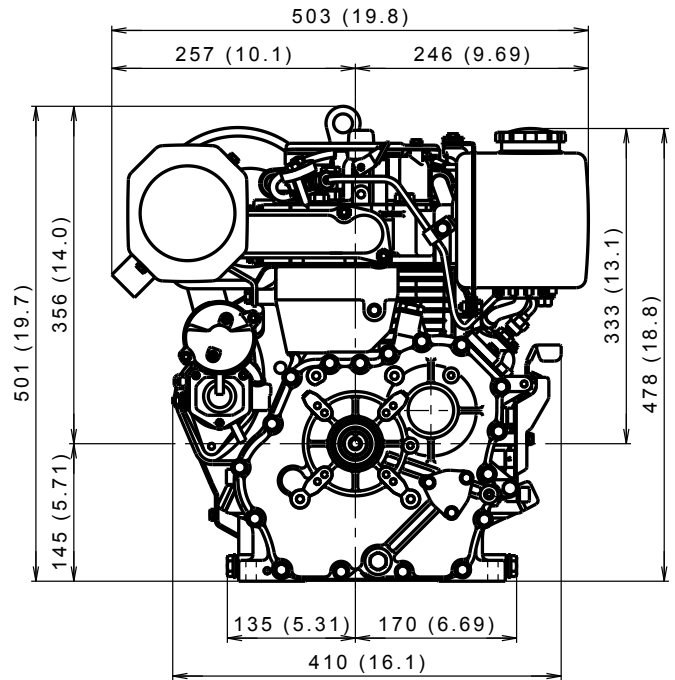

Kubota Corporation

2-47, Shikitsuhigashi 1-chome Naniwa-ku, Osaka, 556-8601 Japan
<https://global.engine.kubota.co.jp/en/>

ASP-OC95-E31806-R1-I-178040

