

## INDUSTRIAL DIESEL ENGINE

Kubota 05 Series (4-Cylinder)

# V1505-E3B (3600 rpm)



### Rated Power

**29.0 kW @ 3600 rpm**

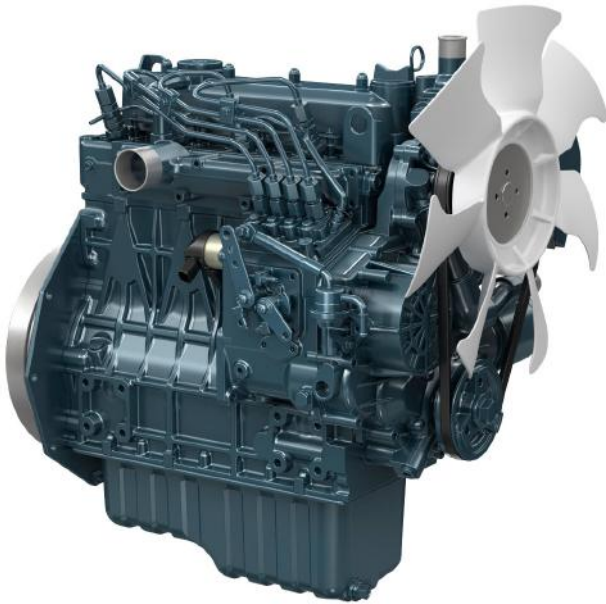

Photograph may show non-standard equipment.

### Performance Curves

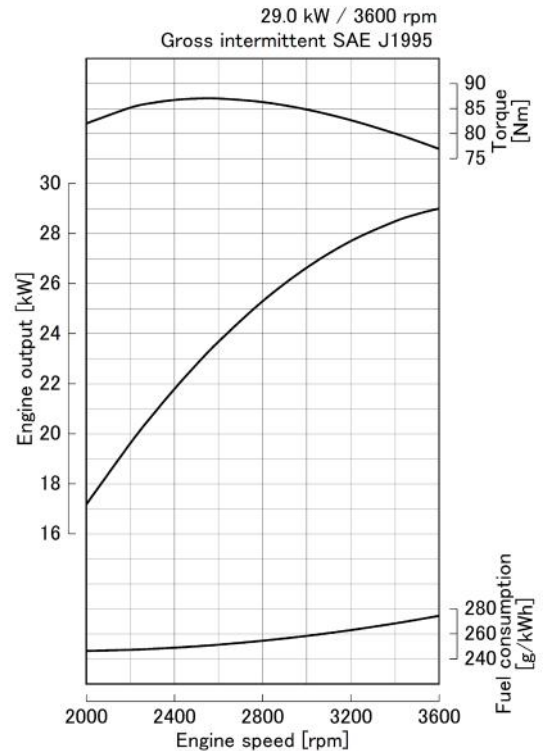

### Features and Benefits

#### Emissions

The V1505 naturally aspirated engine complies with the EPA / CARB interim Tier 4 + EU Stage IIIA emissions regulations.

#### Durable Power

The popular Kubota V1505 naturally aspirated engine offers numerous benefits to applications calling for high speed performance via a compact engine package.

D1505 delivers a smooth transition from EPA Tier 2 to EPA interim Tier 4.

#### Clean and Quiet Power

Kubota's original E-TVCS (Three Vortex Combustion System) has been improved. The airflow, combustion chamber, and piston recess have been optimized to provide low particulate matter (PM) levels, matching the stringent level of emission regulation below 37 kW. The half-float valve cover and MoS<sub>2</sub>-coated pistons reduce noise levels and decrease vibrations transmitted from the valve area.

For Earth, For Life  
**Kubota**

# V1505-E3B (3600 rpm)

## Engine Specifications

<b>Engine model</b>		V1505-E3B (3600 rpm)
<b>Emission regulation</b>		EPA/CARB interim Tier 4 level + EU Stage IIIA
<b>Type</b>		Vertical, water cooled 4-cycle diesel engine
<b>Cylinders</b>		4
<b>Bore and stroke</b>	mm (in)	78.0 x 78.4 (3.07 x 3.09)
<b>Displacement</b>	L (cu.in)	1.498 (91.41)
<b>Aspiration</b>		Naturally aspirated
<b>Aftertreatment</b>		-
<b>Rated output / speed</b> *1	kW (HP) / rpm	29.0 (38.9) / 3600
<b>Maximum torque / speed</b> *1	Nm (lb-ft) / rpm	87.0 (64.2) / 2600
<b>Combustion system</b>		Indirect injection
<b>Fuel system</b>		In-line pump
<b>Length x Width x Height</b> *2 (without aftertreatment unit)	mm (in)	565 x 396 x 607 (22.2 x 15.6 x 23.9)
<b>Length x Width x Height</b> *3 (with aftertreatment unit)	mm (in)	-
<b>Dry weight</b> *3	kg (lbs)	110 (243)

Specifications are subject to change without notice.  
Dimensions and dry weight are according to Kubota's standard specification.  
Dimensions and weight depend on completed specifications.

\*1: SAE J1995 gross intermittent

\*2: Exclude cooling fan and exclude aftertreatment unit

\*3: Exclude cooling fan and include aftertreatment unit on engine

## Dimensions

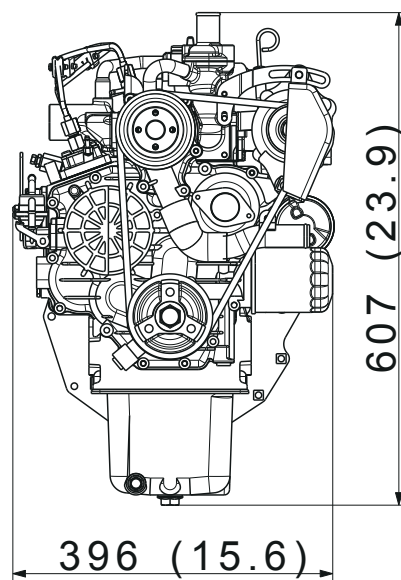
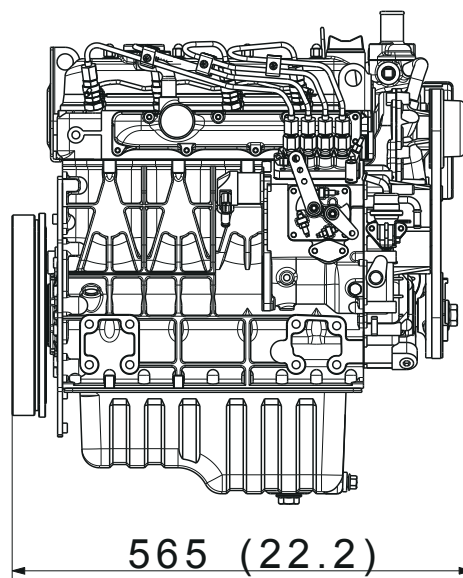

## Kubota Corporation

2-47, Shikitsuhigashi 1-chome Naniwa-ku, Osaka, 556-8601 Japan

<https://engine.kubota.com/en/>

ASP-V1505-E3B361808-R1-I