

INDUSTRIAL DIESEL ENGINE

Kubota 05 Series (4-Cylinder)

V1505-T-E3B



Rated Power

33.0 kW @ 3000 rpm



Photograph may show non-standard equipment.

Performance Curves

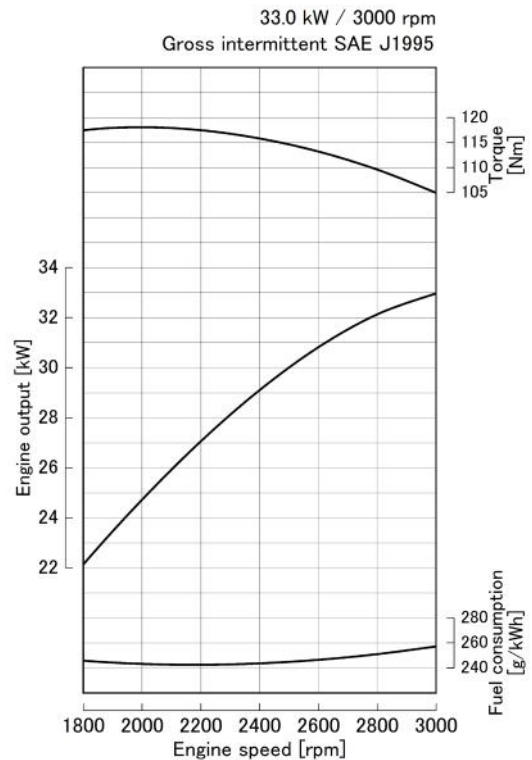

Features and Benefits

Emissions

The V1505 Turbocharged engine complies with EPA / CARB interim Tier 4 + EU Stage IIIA emissions regulations.

Durable Power

The Kubota 05 Series is an established leader in its horsepower range, selected as the power source of choice by various industrial equipment manufacturers.

The V1505-T engine offers a seamless transition from EPA Tier 2 to EPA interim Tier 4 by maintaining the same footprint and hardware mounting points, with no performance changes from Tier 2 engines.

Clean and Quiet Power

The addition of a closed breather system meets EPA interim Tier 4 requirements.

Kubota's original E-TVCS (Three Vortex Combustion System) has been improved. The airflow, combustion chamber, and piston recess have been optimized to provide low particulate matter (PM) levels, matching the stringent level of the 37 kW class and higher (EPA Interim Tier 4 Option 1).

For Earth, For Life

V1505-T-E3B

Engine Specifications

Engine model		V1505-T-E3B
Emission regulation		EPA/CARB interim Tier 4 level + EU Stage IIIA
Type		Vertical, water cooled 4-cycle diesel engine
Cylinders		4
Bore and stroke	mm (in)	78.0 x 78.4 (3.07 x 3.09)
Displacement	L (cu.in)	1.498 (91.41)
Aspiration		Turbocharged
Aftertreatment		-
Rated output / speed *1	kW (HP) / rpm	33.0 (44.3) / 3000
Maximum torque / speed *1	Nm (lb-ft) / rpm	118.6 (87.5) / 2000
Combustion system		Indirect injection
Fuel system		In-line pump
Length x Width x Height *2 (without aftertreatment unit)	mm (in)	565 x 433 x 621 (22.2 x 17.0 x 24.4)
Length x Width x Height *3 (with aftertreatment unit)	mm (in)	-
Dry weight *3	kg (lbs)	114 (251)

Specifications are subject to change without notice.
Dimensions and dry weight are according to Kubota's standard specification.
Dimensions and weight depend on completed specifications.

*1: SAE J1995 gross intermittent

*2: Exclude cooling fan and exclude aftertreatment unit

*3: Exclude cooling fan and include aftertreatment unit on engine

Dimensions

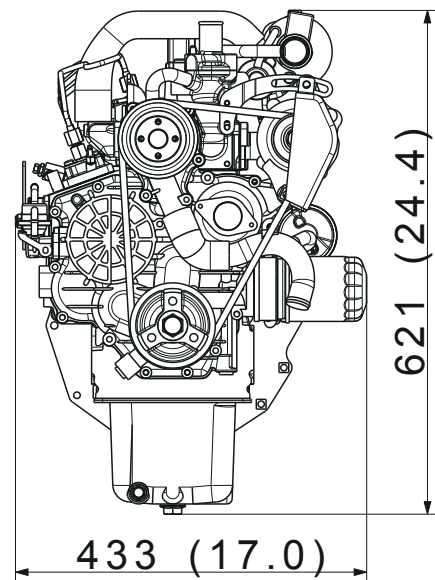
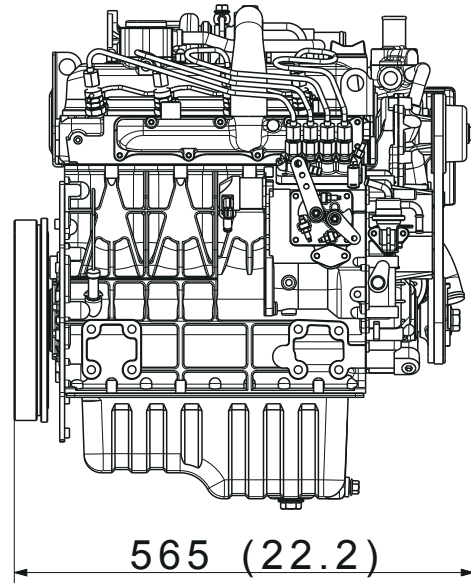

Kubota Corporation

2-47, Shikitsu Higashi 1-chome Naniwa-ku, Osaka, 556-8601 Japan

<https://engine.kubota.com/en/>

ASP-V1505-T-E3B1808-R1-I