

INDUSTRIAL DIESEL ENGINE

Kubota 07 Series (4-Cylinder)

V2607-DI-T-E3B



Rated Power

49.2 kW @ 2700 rpm

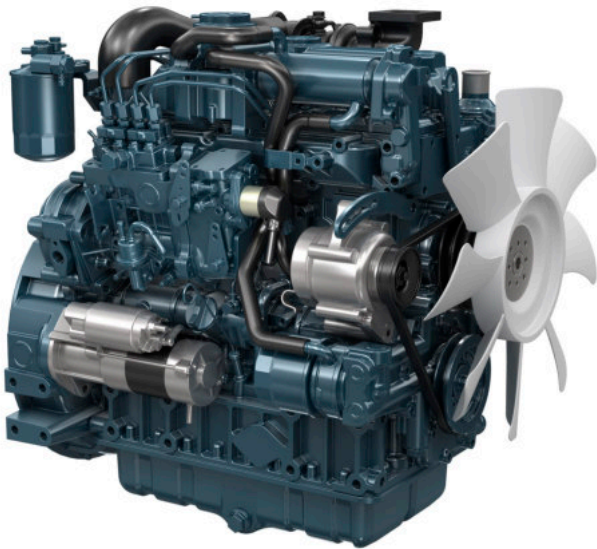

Photograph may show non-standard equipment.

Performance Curves

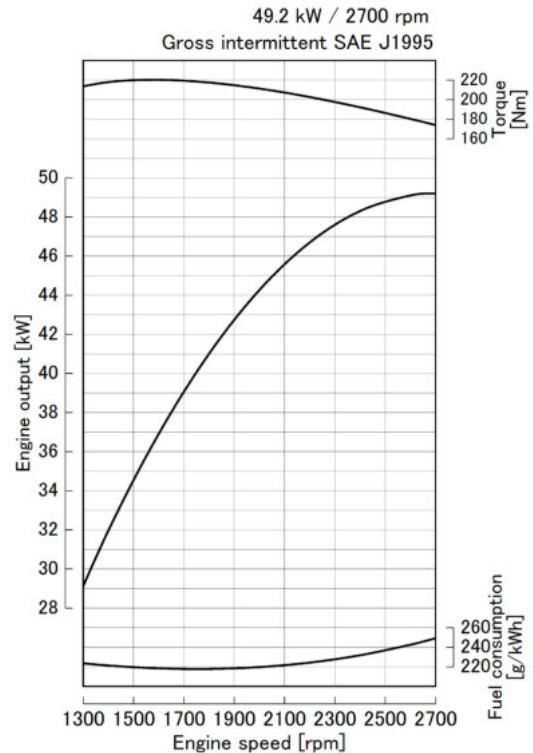

Features and Benefits

07 Series Concept

The Kubota 07 Series features an engine design developed to meet the various requirements of a wide range of industrial applications.

Kubota's unique cylinder block design was developed using our original casting technology. The engine package is smaller than that of the current 2.4L engine, and yet the displacement is larger. The improved cooling system, with a main water gallery and water passages between cylinder bores as a heat load countermeasure, provides high power density and superior endurance in the reliable Kubota 07 Series.

The Kubota 07 Series brings Kubota's seamless range up to 100 HP.

Emissions

Kubota 07 Series engines comply with EPA / CARB interim Tier 4 level + EU Stage IIIA level.

These engines meet emissions regulations with minimal additional required devices. For example, NO_x is reduced by mechanical means alone, including the use of a compact cooled exhaust gas recirculation (EGR) system.

Clean and Quiet Power

Kubota's original E-CDIS (Center Direct Injection System) combustion system, renowned for the clean combustion it provides for the Kubota V3 (DI) Series, has been updated. The fuel injection pressure has been increased and the combustion chamber redesigned to achieve lower particulate matter (PM) levels, resulting in better conditions.

In addition, these engines have been designed to reduce transmitted vibrations and radiated sound, resulting in low noise levels.

Options

A side PTO option is available. This engine offers a power take-off (PTO) located at the gear train on the flywheel side that is designed to enable compact positioning of PTO hydraulic devices.

Fan positions are available at two heights to enable various equipment configurations.

For Earth, For Life
Kubota

V2607-DI-T-E3B

Engine Specifications

Engine model		V2607-DI-T-E3B
Emission regulation		EPA/CARB interim Tier 4 level + EU Stage IIIA level
Type		Vertical, water cooled 4-cycle diesel engine
Cylinders		4
Bore and stroke	mm (in)	87.0 x 110.0 (3.43 x 4.331)
Displacement	L (cu.in)	2.615 (159.6)
Aspiration		Turbocharged
Aftertreatment		-
Rated output / speed *1	kW (HP) / rpm	49.2 (66.0) / 2700
Maximum torque / speed *1	Nm (lb-ft) / rpm	220.3 (162.5) / 1600
Combustion system		Direct injection
Fuel system		In-line pump
Length x Width x Height *2 (without aftertreatment unit)	mm (in)	623 x 481 x 682 (24.5 x 18.9 x 26.9)
Length x Width x Height *3 (with aftertreatment unit)	mm (in)	-
Dry weight *3	kg (lbs)	235 (518)

Specifications are subject to change without notice.
Dimensions and dry weight are according to Kubota's standard specification.
Dimensions and weight depend on completed specifications.

*1: SAE J1995 gross intermittent

*2: Exclude cooling fan and exclude aftertreatment unit

*3: Exclude cooling fan and include aftertreatment unit on engine

Dimensions

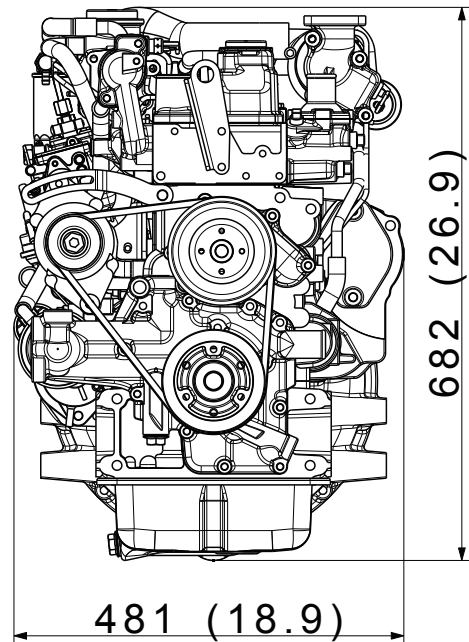
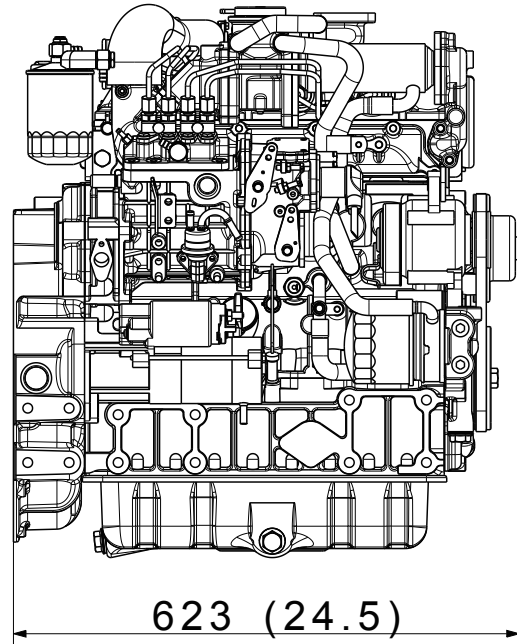

Kubota Corporation

2-47, Shikitsu Higashi 1-chome Naniwa-ku, Osaka, 556-8601 Japan

<https://engine.kubota.com/en/>

ASP-V2607-DI-T-E3B1808-R1-I